

# Christie Q Series

Auditoriums

Boardrooms

Conference rooms

Education

Events

Government

Health care

Houses of worship

Meeting rooms

Rental and staging

Video mapping



*Available in black*

Bringing performance to new  
levels in an affordable solution

**CHRISTIE®**

# Christie Q Series

The Christie® Q Series takes projectors to a new level of high-brightness to bring you the industry's highest-quality 1-chip DLP® projector. Deliver your presentations and video content clearly with image quality that you would expect from Christie. With a range of projection options, sleek overall style and high-performance features, the Christie Q Series brings you superior image processing, versatility and affordability.



## Best-in-class brightness

Christie DXG1051-Q  
XGA – 10,000 ANSI lumens

Christie DHD951-Q  
HD – 8200 ANSI lumens

Christie DWX951-Q  
WXGA – 8500 ANSI lumens

Christie DWU951-Q  
WUXGA – 8500 ANSI lumens

# Advanced features for superior image quality

## eClarity

Our eClarity advanced image processing enhances your content by improving sharpness, gloss and shading, perfect for making non-HD content look like HD. Use eClarity to improve your standard and high-definition content for a brilliant, true-to-life image reproduction.



▲ Unadjusted image

▲ Adjusted image



▲ Sharpen

▲ Gloss

▲ Shade

## Built-in dual-color wheel

A set of two color wheels are built into the projector and can be selected at a touch of a button. The built-in color wheels allow for easy switching between high brightness or ultra-rich color reproduction mode, perfect for your presentation needs. In large venues the high brightness color wheel gives you maximum output and superior white levels. The ultra-rich color wheel expands the color gamut for incredible reproduction that rivals cinema color standards.

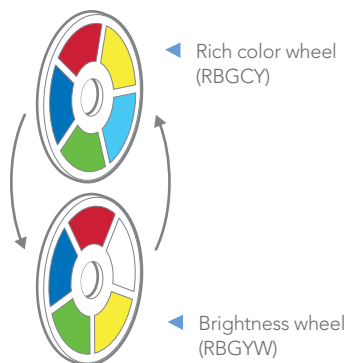

## High Dynamic Contrast Range

High Dynamic Contrast Range (HDCR) improves visual contrast to avoid giving content a washed out effect in environments with a lot of ambient light. HDCR helps by adjusting the dynamic contrast level which will help recapture detail lost by excess ambient light on the screen.



◀ HDCR off



◀ HDCR on

## Advanced image control

Motion-adaptive de-interlace delivers improved viewing of video content and fast-moving motion graphics. On-image display of gamma and color balance equalization allows you to manipulate your image configuration in real time.



◀ Standard video capture



◀ Digital rapid motion adaptive de-interlacer

## Designed for performance

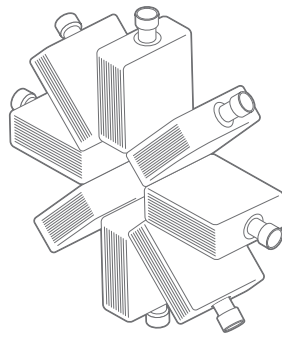

▲ 360 degree projection



▲ Standard mode



▲ DICOM simulation mode

### Blending or warping capabilities

Blending or warping are easy with the new Q Series software and the use of off-the-shelf standard cameras<sup>1</sup>. The software and camera option allow for easy and quick edge-blending capabilities. You can also use the software to set up multiple projectors for warping images (advanced geometry correction) or for multi projector blending to create large panoramic seamless display.

### Broad variety of lensing options

New lens shift capability with our ultra-short throw lenses allows you to install projectors as close as necessary to your projected image without compromising display size.

Multiple screens, or creative projection on multiple areas, are not a problem with up to three memory settings for lens shift, zoom and focus recalls.

### Portrait mode and 360 degree projection

Projectors can be used in portrait orientation using existing lamps, reducing your set-up time and minimizing extra costs for special lamps. They can also be installed in a 360 degree configuration.

### Enhanced lamp options

Dual-lamp design lets you maximize brightness or extend lamp life. Lamps can be used in relay, eco, auto backup and balance mode. Lamp life is up to 2000 hours for standard mode, up to 4000 hours for eco 2-lamp and up to 8000 hours in optional lamp relay modes. The lamps are also designed to be swapped out without shutting down the projector<sup>2</sup>.

### Connectivity

HDBaseT provides the latest in intelligent and flexible connectivity, simplifying installation and management by allowing for video content, audio and control to be delivered over low cost CAT5/6e cabling to HDBaseT-compatible products.

### Digital Imaging and Communication in Medical (DICOM) simulation

DICOM simulation mode provides enhanced grey scale levels for medical training<sup>3</sup> applications requiring DICOM part 14 specifications.

### Built-in LCD information display

The LCD display gives you real-time diagnostic information, assisting in network setup or helping with troubleshooting. Examples of some display options:

Lamp time
Filter hours
Projector usage
IP address

<sup>1</sup> Logitech : HD Pro Webcam C910 / HD Pro Webcam C920; Canon Digital SLR: T1i / T2i / T3 / T3i.

<sup>2</sup> Please reference manual for activating feature.

<sup>3</sup> Simulation mode is for training purposes only, not for medical diagnostics of actual patients.



## Variety of lens options to choose from

Our suite of lenses give you the range to install from a 0.8:1 all the way to a 9.2:1 throw ratio<sup>4</sup>.



### Lens options<sup>4</sup>

Description	Part number
0.8-1.0 ultra short throw zoom	121-118101-01
1.2-1.8/1.1-1.7 short throw zoom	121-119102-01
1.7-2.6/1.6-2.4 standard zoom (WXGA/WUXGA)	121-120104-01
1.7-2.5 standard zoom (XGA)	121-121105-01
2.5-3.8/2.4-3.6 middle throw zoom	121-122106-01
3.6-5.8/3.7-5.9/3.5-5.6 long throw zoom	121-123107-01
5.7-9.1/5.8-9.2/5.5-8.8 ultra long throw zoom	121-124108-01

### Wireless presentation and projector control

Using Christie® Q Series projectors and the Christie QuickConnect App you can project photos, documents and websites over Wi-Fi® from your iOS or Android™ based mobile digital devices.



◀ Choice between black or white models in every resolution

<sup>4</sup> Throw ratio varies by resolution. See [www.christiedigital.com](http://www.christiedigital.com) for further information.

# Going above and beyond

In addition to high quality products, what makes Christie® different from everyone else?

We go above and beyond to take care of our customers. Customers keep coming back to us because they can't get the same level of support anywhere else.

We care about our customers. Your satisfaction is our ultimate goal. We stand behind our products, and support you with our industry recognized warranty and service programs.



## Christie support and service

All Christie products are backed by industry-leading warranties, renowned service and support. We ensure our customers are well supported with training, service and technical support through our extensive distribution and support network.

Christie has local support on five continents offering support for international installations and global deployments.

We offer customer-centric service with years of extensive experience in varieties of applications.

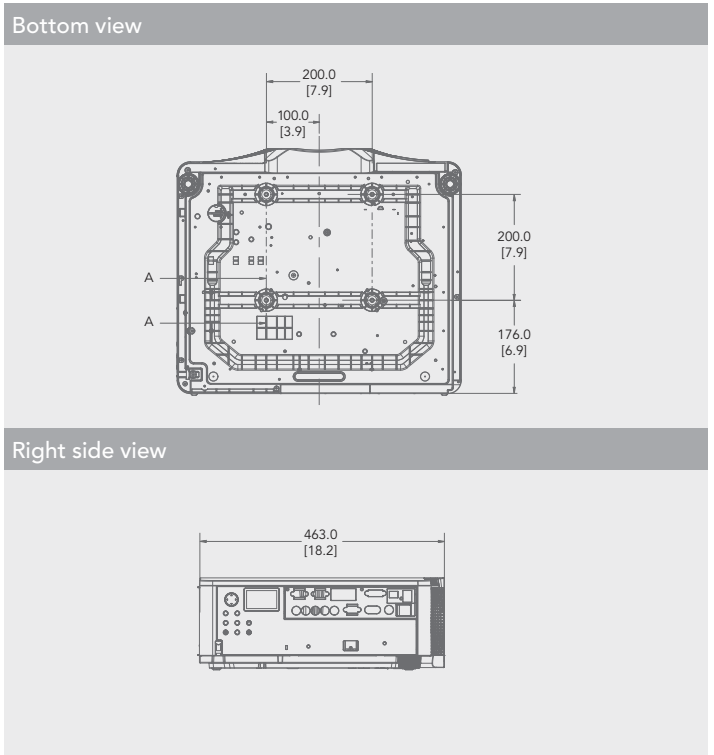
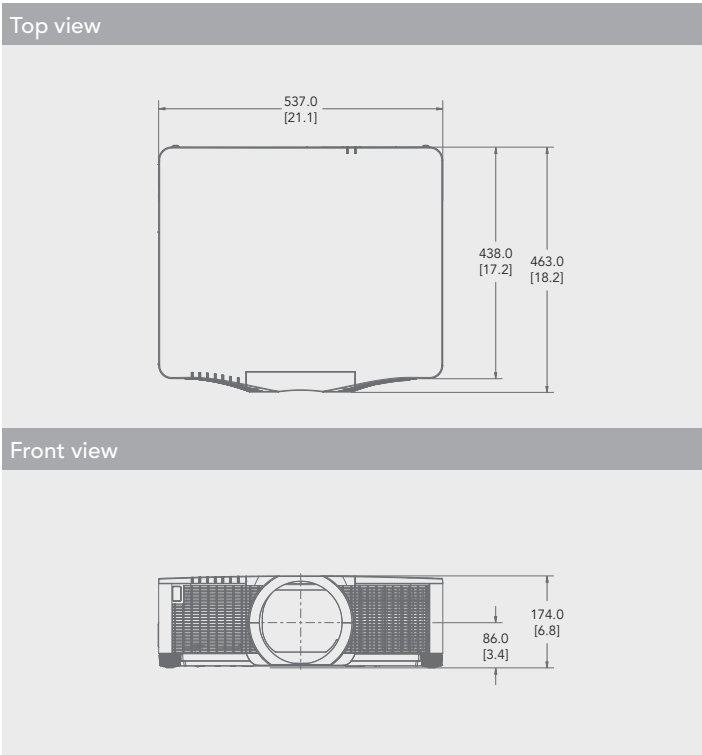

		Christie DXG1051-Q	Christie DWX951-Q	Christie DHD951-Q	Christie DWU951-Q
Image	brightness	• 10,000 ANSI lumens – (10,400 center lumens)	• 8500 ANSI lumen – (8900 center lumens)	• 8200 ANSI lumens – (8500 center lumens)	• 8500 ANSI lumens – (8900 center lumens)
	contrast	• 2000:1 full on/off	• 2500:1 full on/off		
	uniformity	• ≤90% brightness uniformity			
Display	type	• 1-chip 0.7" DLP	• 1-chip 0.65" DLP	• 1-chip 0.65" DLP	• 1-chip 0.67" DLP
	native resolution	• XGA (1024 x 768)	• WXGA (1280 x 800)	• HD (1920 x 1080)	• WUXGA (1920 x 1200)
	color wheels	• Built-in color wheel (CW) options: high brightness CW segments = RGBYW/ultra rich CW segments = RGBYC			
Lamp	type	• 370W P-VIP x 2			
	typical lifetime	• Standard mode: up to 2000 hrs • Eco mode: up to 4000 hrs		• Portrait mode: up to 1000 hrs	• Portrait mode: up to 500 hrs
Inputs	standard	• Computer D-sub 15 pin mini jack x 1 • BNC connector x 1 (composite) • HDMI connector x 2			
		• DVI-D connector x 1 /RJ-45 x 1 (HDBaseT) • D-sub 9 pin x 1 (RS232c) • RJ-45 x 1 (LAN)			
		• USB type A connector x 1 (Optional Wireless USB or PC-less) • Wired remote control (3.5mm)			
		• 5BNC connector x 1 • BNC connector x 1 (composite)	• 3G-SDI (only available on DHD951-Q)	• 5BNC connector x 1 • BNC connector x 1 (composite)	
	optional	• Optional wireless dongle (USB)			
	signals	• 525i(480i) • 525p(480p) • 625i(576i) • 1125i(1080i@50/60) • 750p(720p@50/60) • 1125p(1080p@50/60)			
	pixel clock	• 27 ~ 150 MHz			
Outputs	standard	• Computer out D-sub 15 pin mini jack x 1 • Wired remote control (3.5mm)			
Control and networking		• RJ-45 x 1 (LAN) • RJ-45 x 1 (HDBaseT) • D-sub 9 pin x 1 (RS232c)			
Lenses		• For further details on lenses, please see www.christiedigital.com			
Accessories	standard	• Power cord (US cord, 3m) / (Euro code, 3m) / Power cord (China cord, 3m only for China models) • RGB cable (2m)			
		• Wireless remote control / AA batteries x 2 • Adapter cover • Ferrite core and band x 2 • Cable tie x 2			
	optional	• User's manual CD (safety guide) • Quick setup guide • Network quick setup guide • Operating guide • Network guide			
		• Network guide • Instant stack guide • Technical guide • Software license agreement x 1 • User's manual			
		• Replacement lamp (003-004774-XX)	• Replacement lamp (003-005053-01)	• Replacement lamp (003-004774-XX)	
		• Replacement hybrid filter (003-004775-X)			
		• Optional wireless dongle (USB) (121-116109-XX) • Replacement remote			
Enhanced feature sets		• 2 HDMI input • eClarity and HDCR • Built in ultra rich color wheel • HDBaseT • Portrait mode capable			
		• Edge blending • Geometric correction • Status monitor display • Motorized zoom, focus and lens shift with memory			
		• PC-less presentation • 3G-SDI			
Power requirements	operating voltage	• 110-120 VAC • 220-240 VAC			
	consumption	• AC110-120V, 50/60Hz 1060W • AC220-240V, 50/60Hz 990W			
		• Less than 0.5W @ standby with saving. (AC230V) • Saving mode disables MONITOR OUT, AUDIO OUT, speaker sound, LAN communication and RS232C control except Power ON command in standby			
	operating current	• 10.5A +10% or less at 110-120VAC • 5.2A+10% or less at 220-240 VAC			
	dissipation	• 3618 BTU/hr (110-120V) • 3379 BTU/hr (220-240V)			
Physical specs	size	• (LxWxH) 18.2 x 21.1 x 6.9" (463 x 537 x 174mm) without lens and feet in minimum position			
	shipping size	• (LxWxH) 22.1 x 29.3 x 12.4" (561 x 743 x 315mm) without lens and feet in minimum position			
	weight	• 37.5lbs (17kg)			
	shipping weight	• 49.6lbs (22.5kg)			
Operating environment	noise	• Standard mode: 36dBA • Eco mode: 29dBA			
	operating temperature	• 32-113°F (0-45°C) from sea level to 5249ft (1600m)			
		• 32-104°F (0-40°C) from 5249ft (1600m) to 10,000ft (3048m)			
	altitude	• 0-10,000ft (3048m)			
	humidity	• 10-80% non-condensing			
Regulatory		• This product conforms to the following regulations related to product safety, environmental requirements and electromagnetic compatibility (EMC) • FCC, Part 15, Subpart B, Class A • EN55022/CISPR22 Class A • ICES/NMB003 (A)			
		• EN55024 / CISPR24 • IEC 60950-1 • UL 60950-1 • EN 60950-1 • CAN/CSA C22.2 No. 60950-1 • Directive 2011/65/EU (RoHS)			
		• Directive 2012/19/EU (WEEE) • EU Regulation (EC) No. 1907/2006 (REACH)			
		• Certifications marks (check with Christie for latest update): cULus (Canada & US), CE (EU), CCC (China), EAC (Russia), RCM (Australia and New Zealand), India (BIS), Mexico (NOM), Saudi Arabia, South Africa			
Limited warranty		• Three years parts and labor limited warranty • Lamp: 500 hours or one year (whichever comes first)			
		• Contact an authorized Christie representative for full details of our limited warranty			



#### Corporate offices

Christie Digital Systems USA, Inc  
USA – Cypress  
ph: 714 236 8610

Christie Digital Systems Canada Inc.  
Canada – Kitchener  
ph: 519 744 8005

#### Independent sales consultant offices

Italy  
ph: +39 (0) 2 9902 1161

#### Worldwide offices

Australia  
ph: +61 (0) 7 3624 4888

Brazil  
ph: +55 (11) 2548 4753

China (Beijing)  
ph: +86 10 6561 0240

China (Shanghai)  
ph: +86 21 6278 7708

Eastern Europe and  
Russian Federation  
ph: +36 (0) 1 47 48 100

France  
ph: +33 (0) 1 41 21 44 04

Germany  
ph: +49 2161 664540

India  
ph: +91 (080) 6708 9999

Japan (Tokyo)  
ph: 81 3 3599 7481

Korea (Seoul)  
ph: +82 2 702 1601

Republic of South Africa  
ph: +27 (0)11 510 0094

Singapore  
ph: +65 6877 8737

Spain  
ph: +34 91 633 9990

United Arab Emirates  
ph: +971 4 3206688

United Kingdom  
ph: +44 (0) 118 977 8000



ISO 9001  
ISO 14001

Kitchener, Ontario



For the most current specification information, please visit [www.christiedigital.com](http://www.christiedigital.com)



Copyright 2014 Christie Digital Systems USA, Inc. All rights reserved. All brand names and product names are trademarks, registered trademarks or tradenames of their respective holders. Christie Digital Systems Canada Inc.'s management system is registered to ISO 9001 and ISO 14001. Performance specifications are typical. Due to constant research, specifications are subject to change without notice. Printed in Canada on recycled paper. 3857 Jun 14

**CHRISTIE®**